



NXZ(H)B、NXZ(H)M Series ATS

1. General

1.1 Scope of Application

1.1.1 NXZ(H)B/NXZ(H)M Series Automatic Transfer Switching Equipment is applicable to three-phase four-wire duplicate supply grid of AC 50/60Hz, rated voltage 400V/415V and below, rated current 800A, and can switch one or several load circuits from one power source to the other to ensure the normal power supply of the load circuit.

1.1.2 This product is applicable to industrial and commercial power use places, high-rise buildings, and residential houses.

1.2 Applicable standards

1.2.1 Product standard

- IEC 60947-1.
- IEC 60947-6-1.

1.2.2 Standards for use in extreme environment

- IEC 60068-2-1. (Low Temperature)
- IEC 60068-2-2. (High Temperature)
- IEC 60068-2-30. (Cyclic Damp Heat)
- IEC 60068-2-11. (Salt mist)

1.3 Normal working conditions

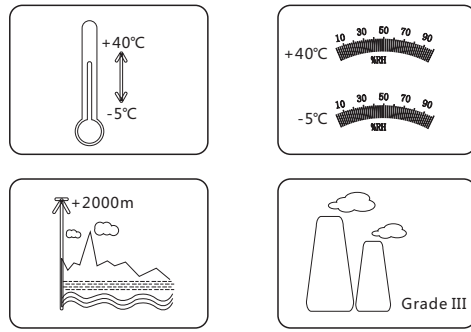

1.3.1 Ambient temperature

-5°C~+40°C; Users can custom-tailor relevant product to be used in the environment of -25°C~+70°C, and use the product according to the temperature compensation table.

1.3.2 Sea level elevation

Equal to 2000m or below; if it needs to work above 2000m altitude, it shall be used according to the table of capacity reduction of different altitudes.

1.3.3 Atmospheric conditions

The relative humidity shall not exceed 50% when the surrounding air temperature is +40°C; the relative humidity can be higher when the temperature is lower; the average monthly maximum relative humidity in the wettest month is 90%, and the average monthly minimum temperature shall be +20°C. Special measures may be necessary in cases of occasional condensation due to variations in temperature.

1.3.4 Pollution degree: class 3

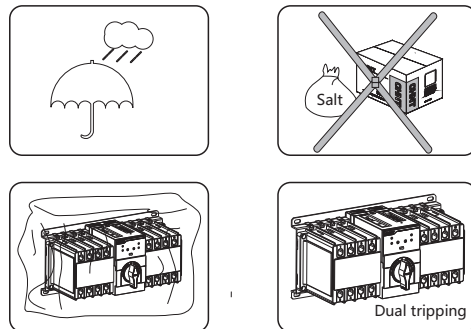

1.3.5 Installation category

Installation category of the switching equipment of main circuit is category IV.

Installation category of auxiliary circuit is category III.

Installation category of conversion controller is category II.

1.3.6 Utilization category:

- NXZB: AC-33iB
- NXZ (H) B: AC-33B
- NXZ (H) M: AC-33B

1.3.7 Electromagnetic compatibility (EMC)

- Electrostatic discharge (IEC 61000-4-2) Level 2
- Radio-frequency electromagnetic field-radiated electromagnetic field immunity (IEC 61000-4-3) Level 3,
- Fast transient bursts (IEC 61000-4-4) Level 3,
- Surges (IEC 61000-4-5) Level 3, Radio-frequency electromagnetic field-conducted immunity (IEC 61000-4-6) Level 3, Radiation grade (CISPR11) grade B,

2. Model definition and description

NXZB-63 (Class CB)

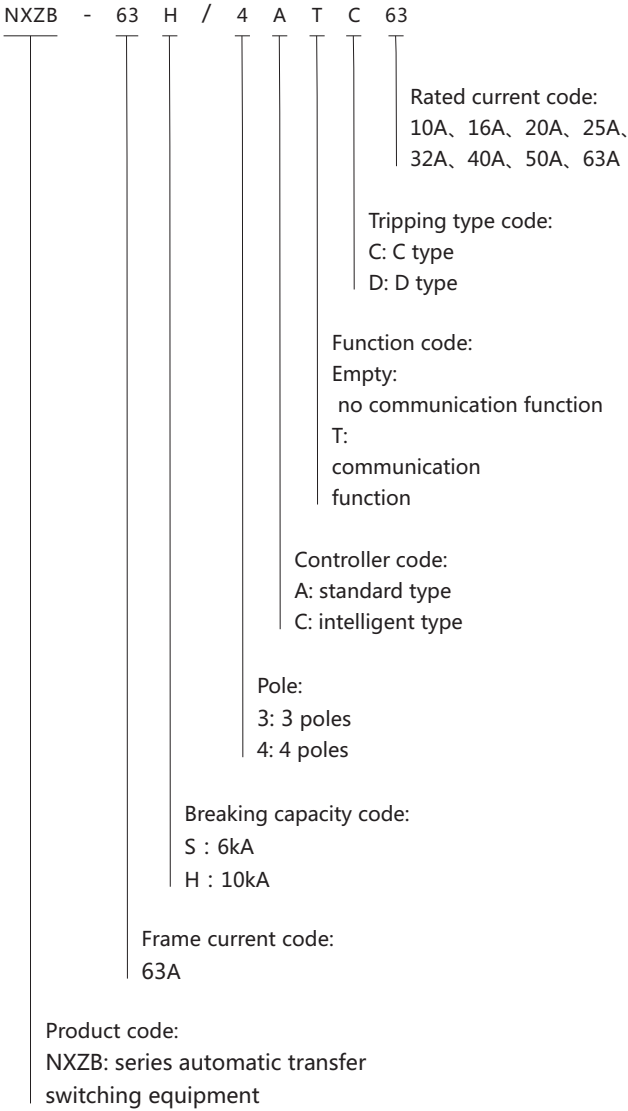

NXZM (Class CB)

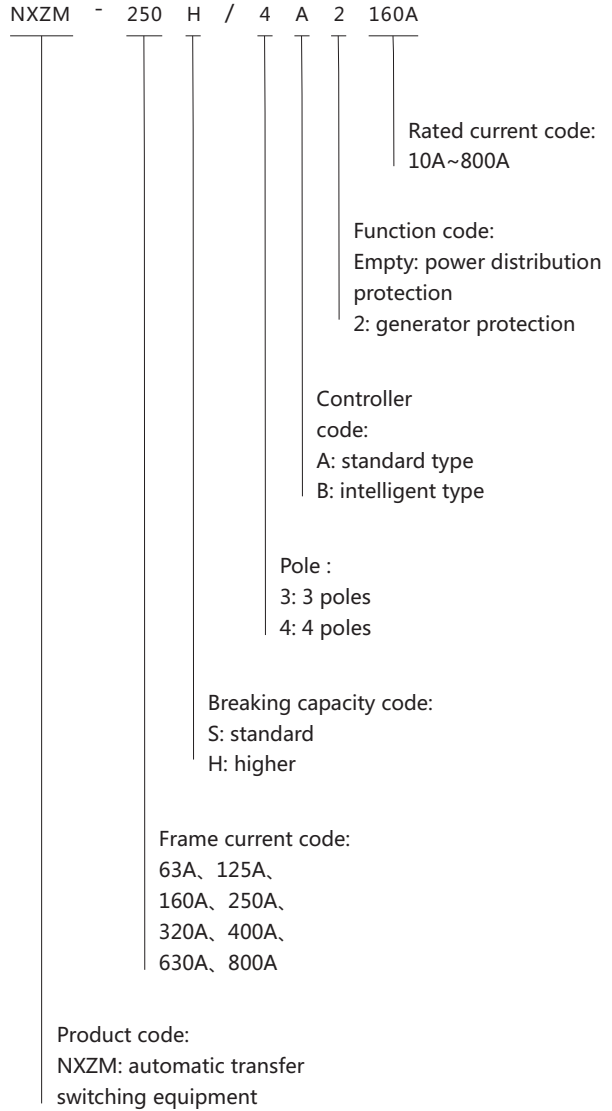

Type selection example:

NXZB-63H/4C C63: To order a class CB automatic transfer switching equipment, the frame current is 63A, number of poles is 4P, the breaking capability is 10kA, rated current is 63A, the tripping type is C type, with an intelligent controller (C type).

Type selection example:

NXZM-250H/4A 160A: To order a class CB automatic transfer switching equipment, the frame current is 250A, number of poles is 4P, H breaking capability, rated current is 160A, with a standard controller (A type) and generator protection.

Comparison Table of Frame Current and Rated Current

Rated current (A)	10	16	25	32	40	50	63	80	100	125	160	180	200	225	250	315	320	350	400	500	630	700	800	
Frame current (A)	63	■	■	■	■	■	■																	
	125						■	■	■	■														
	160									■	■													
	250										■	■	■	■	■									
	320														■		■							
	400														■	■		■	■					
	630																		■	■	■			
	800																					■	■	■

NXZHB-63 (Class PC)

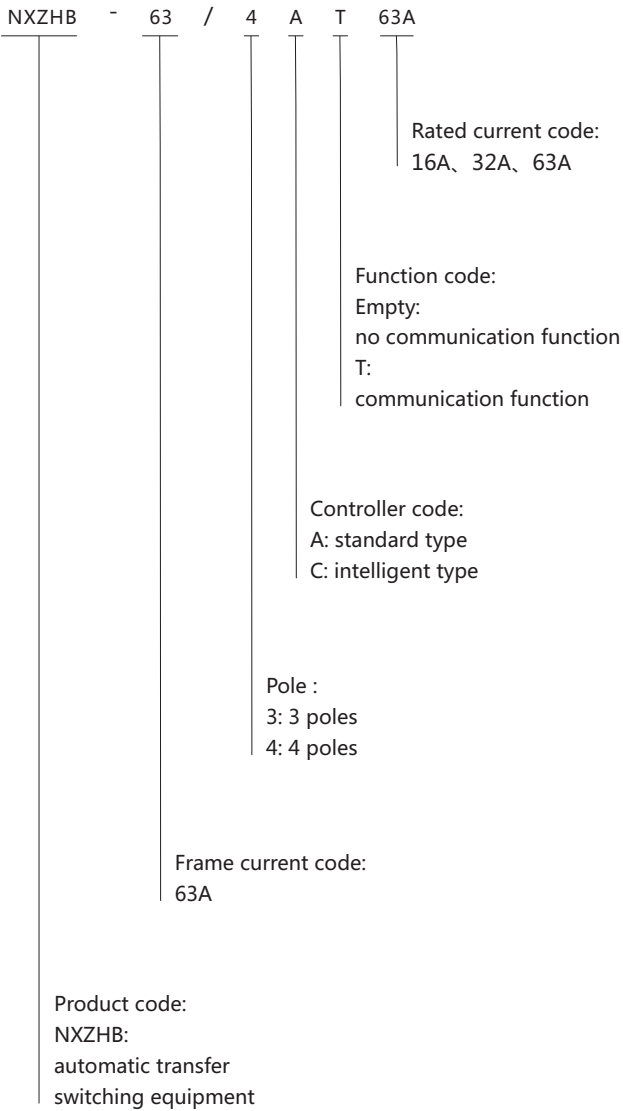

NXZHM (Class PC)

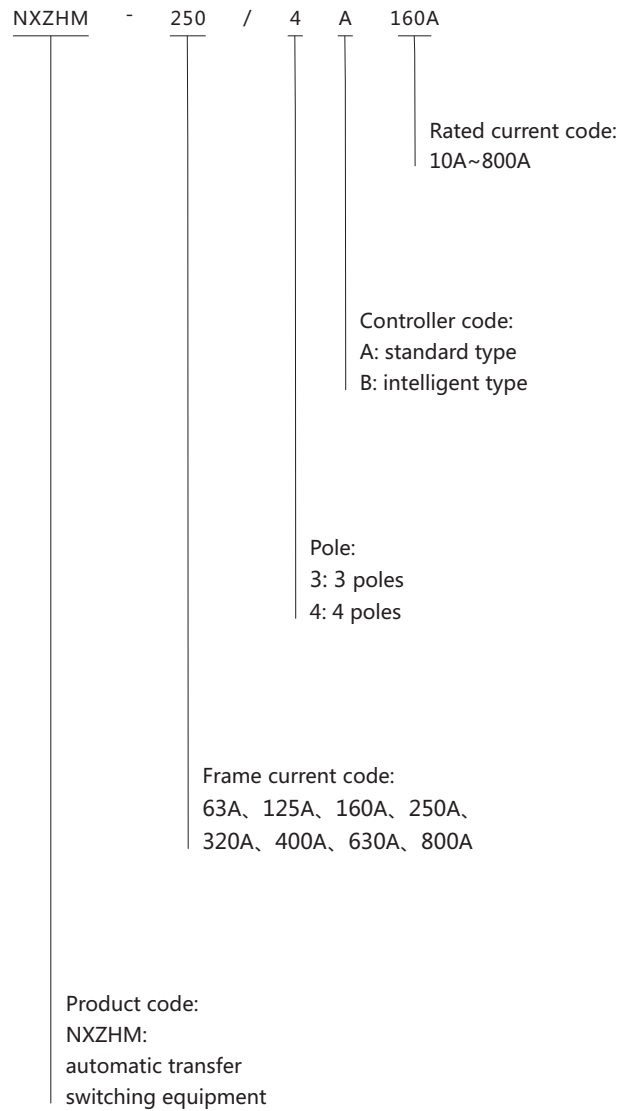

Type selection example:

NXZHB-63/4A 63A: To order a PC grade automatic transfer switching equipment, the frame current is 63A, number of poles is 4P, rated current is 63A, with a standard controller (A type).

Type selection example:

NXZHM-250/4A 250A: To order a PC grade automatic transfer switching equipment, the frame current is 250A, number of poles is 4P, rated current is 250A, with a standard controller (A type)

Comparison Table of Frame Current and Rated Current

Rated current (A)	10	16	25	32	40	50	63	80	100	125	160	180	200	225	250	315	320	350	400	500	630	700	800	
Frame current (A)	63	■	■	■	■	■	■																	
	125						■	■	■	■														
	160									■	■													
	250										■	■	■	■	■									
	320														■			■						
	400														■	■		■	■					
	630																			■	■	■		
	800																					■	■	■



3. Functions and characteristics

Technical parameters of NXZB-63 (class CB)

Model	NXZB-63S	NXZB-63H
Electrical characteristics		
Execution body	NXB-63	NXB-63H
Frame current (A)	63	63
Rated current (A)	10, 16, 20, 25, 32, 40, 50, 63	10, 16, 20, 25, 32, 40, 50, 63
Rated operational voltage Ue (V)	400	400
Rated insulation voltage Ui (V)	500	500
Rated impulse voltage Uimp (kV)	4	4
Utilization category	AC-33iB	AC-33iB
Number of poles	3P, 4P	3P, 4P
Rated short-circuit making capacity Icm (kA)	9	17
Rated short-circuit breaking capacity Icn (kA)	6	10
Tripping curve type	C, D	C, D
Mechanical endurance (times)	10000	10000
Electrical endurance (times)	3000	3000
Controller characteristics		
Controller model	A type (standard), C type (intelligent)	
Operating transfer time (s)	1.4 × (1±10%)	
Controller installation mode	Built in	
Rated control power source voltage Us(V)	230 50Hz	
Control voltage range	85%Ue~110%Ue	

Technical parameters of NXZM (class CB)

Model	NXZM-63	NXZM-125	NXZM-160	NXZM-250	NXZM-320	NXZM-400	NXZM-630	NXZM-800
Electrical characteristics								
Execution body	NXM-63	NXM-125	NXM-160	NXM-250	NXM-320	NXM-400	NXM-630	NXM-800
Frame current (A)	63	125	160	250	320	400	630	800
Rated current (A)	10, 16, 25, 32, 40, 50, 63	63, 80, 100, 125	125, 160	160, 180, 200, 225, 250	160, 180, 200, 225, 250, 320	250, 315, 350, 400	400, 500, 630	630, 700, 800
Rated operational voltage Ue (V)	400/415 50Hz							
Rated insulation voltage Ui (V)	AC800	AC800	AC800	AC1000	AC1000	AC1000	AC1000	AC1000
Rated impulse voltage Uimp (kV)	8					12		
Use type	AC-33B							
Number of poles	3P, 4P							
Rated short-circuit making capacity Icm (kA)	S : 52.5 H : 105	S : 52.5 H : 105	S : 73.5 H : 105	S : 73.5 H : 105	S : 73.5 H : 105	S : 105 H : 143	S : 105 H : 143	S : 105 H : 165
Rated short-circuit breaking capacity Icn (kA)	S : 25 H : 50	S : 25 H : 50	S : 35 H : 50	S : 35 H : 50	S : 35 H : 50	S : 50 H : 65	S : 50 H : 65	S : 50 H : 75
Mechanical endurance (times)	10000	10000	8000	6000	6000	4000	4000	4000
Electrical endurance (times)	2000	2000	2000	2000	2000	1500	1500	1000
Controller characteristics								
Controller model	A type (standard), B type (intelligent)							
Operating transfer (s)	2.8 × (1±10%)	2.8 × (1±10%)	3.3 × (1±10%)	3.3 × (1±10%)	3.3 × (1±10%)	3.5 × (1±10%)	3.5 × (1±10%)	4 × (1±10%)
Installation mode	Integrated, split							
Rated control power source voltage Ue(V)	230/240 50Hz							
Control voltage range	85%~110%Ue							

Technical parameters of NXZHB-63 (class PC)

Model	NXZHB-63
Electrical characteristics	
Frame current (A)	63
Rated current (A)	16, 32, 63A
Rated operational voltage Ue (V)	400
Rated insulation voltage Ui (V)	500
Rated impulse voltage Uimp (kV)	4
Utilization category	AC-33B
Number of poles	3P, 4P
Rated conditional short-circuit current Iq (kA)	100
Mechanical endurance (times)	10000
Electrical endurance (times)	1500
Controller characteristics	
Controller model	A type (standard), C type (intelligent)
Operating transfer (s)	1.4 × (1±10%)
Controller installation mode	Built in
Rated control power source voltage Ue(V)	230 50Hz
Control voltage range	85%Ue~110%Ue

Technical parameters of NXZHM (class PC)

Model	NXZHM-63	NXZHM-125	NXZHM-160	NXZHM-250	NXZHM-320	NXZHM-400	NXZHM-630	NXZHM-800
Electrical characteristics								
Execution body	NXHM-63	NXHM-125	NXHM-160	NXHM-250	NXHM-320	NXHM-400	NXHM-630	NXHM-800
Frame current (A)	63	125	160	250	320	400	630	800
Rated current (A)	10, 16, 25, 32, 40, 50, 63	63, 80, 100, 125	125, 160	160, 180, 200, 225, 250	160, 180, 200, 225, 250, 320	250, 315, 350, 400	400, 500, 630	630, 700, 800
Rated operational voltage Ue (V)	400/415 50Hz							
Rated insulation voltage Ui (V)	AC800	AC800	AC800	AC1000	AC1000	AC1000	AC1000	AC1000
Rated impulse voltage Uimp (kV)	8					12		
Utilization category	AC-33E							
Number of poles	3P, 4P	3P, 4P	3P, 4P	3P, 4P	3P, 4P	3P, 4P	3P, 4P	3P, 4P
Rated conditional short-circuit current Iq (kA)	100	100	100	100	100	100	100	100
Mechanical endurance (times)	10000	10000	8000	6000	6000	4000	4000	4000
Electrical endurance (times)	2000	2000	2000	2000	2000	1500	1500	1000
Controller characteristics								
Controller model	A type (standard), B type (intelligent)							
Operating transfer (s)	2.8 × (1±10%)	2.8 × (1±10%)	3.3 × (1±10%)	3.3 × (1±10%)	3.3 × (1±10%)	3.5 × (1±10%)	3.5 × (1±10%)	4 × (1±10%)
Installation mode	Integrated, split							
Rated control power source voltage Us(V)	230/240 50Hz							
Control voltage range	85%~110%Ue							

4. Functions and characteristics

Functional parameters of NXZ (H) B controller

Function	Model	A type (standard)	C型 (智能型)
Manual/automatic transfer		■	■
Main contact positions			
Normal position		■	■
Alternative position		■	■
Off-position		■	■
Automatic control			
Normal supply of monitoring		■ Phase failure/loss of voltage, undervoltage, overvoltage fault	■ Phase failure/loss of voltage, undervoltage, overvoltage fault
Alternative supply of monitoring		■ Phase failure/loss of voltage, undervoltage, overvoltage fault	■ Phase failure/loss of voltage, undervoltage, overvoltage fault
Automatically transfer and restore operation		■	■
Grid-grid		■	■
Phase failure/loss of voltage transfer		■	■
Undervoltage transfer		■	■
Delay adjustable		■	■
Transfer delay		0s~30s adjustable	0s~30s adjustable
Return delay		0s~30s adjustable	0s~30s adjustable
Generator control		-	Optional
Fire control linkage		■	■
Fire control feedback		■	■
Indication			
Switching-on/switching-off/dual tripping indication		■	■
Normal/alternative supply indication		■	■
Parameter setting indication			
Others			
Communication function		Optional	Optional

Table of main functional parameters of NXZ (H) M controller

Function	Model	A type (standard)	B type (intelligent)
Manual/automatic transfer		■	■
Main contact positions			
Normal position		■	■
Alternative position		■	■
Off-position		■	■
Automatic control			
Normal supply of monitoring		■ Phase failure/loss of voltage, undervoltage, overvoltage fault	■ Phase failure/loss of voltage, undervoltage, overvoltage fault
Alternative supply of monitoring		■ Phase failure/loss of voltage, undervoltage, overvoltage fault	■ Phase failure/loss of voltage, undervoltage, overvoltage fault
Automatically transfer and restore operation		■	■
Automatically transfer and nonautomatically restore operation		■	■
Grid-grid		■	■
Grid-generator		-	-
Phase failure/loss of voltage transfer		■	■
Undervoltage transfer		■	■
Overvoltage transfer		■	■
Delay adjustable		■	■
Transfer delay		0s~180s adjustable	0s~180s adjustable
Return delay		0s~180s adjustable	0s~180s adjustable
Generator control		-	■
Fire control linkage		■	■
Fire control feedback		■	■
Indication			
Switching-on/switching-off/off-position		■	■
Normal/alternative supply indication		■	■
Parameter setting indication		■	■
Fault tripping indication		■	■
Others			
Communication function		Optional	Optional
Display module		■ LED	■ LED

Functional description of NXZ (H) B

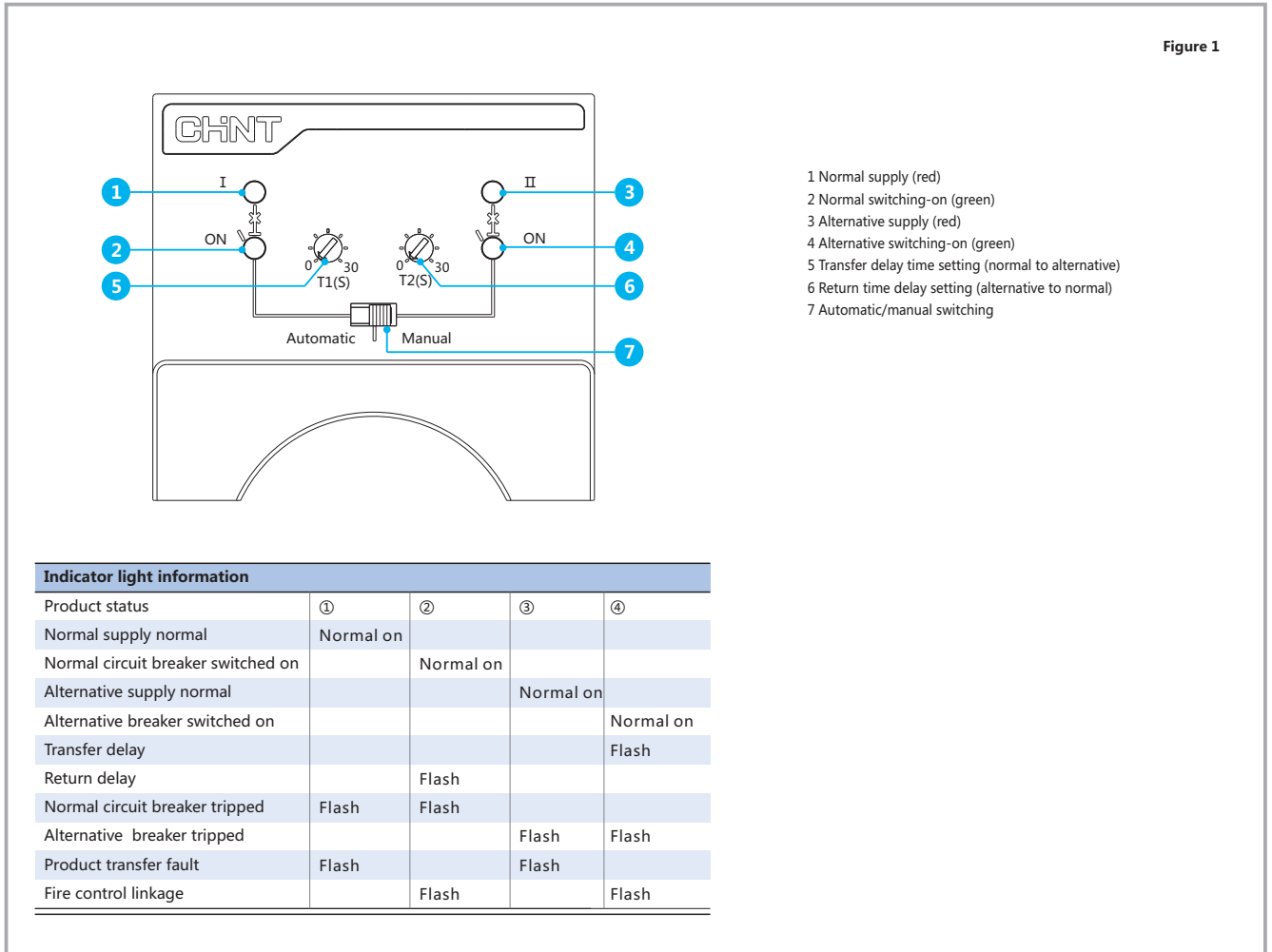

Lock system

During line repair or fault-based maintenance, put the product on off-position, and then pull out the locking system of the handle, then lock it. The lock hole diameter is $\Phi 5.5$.

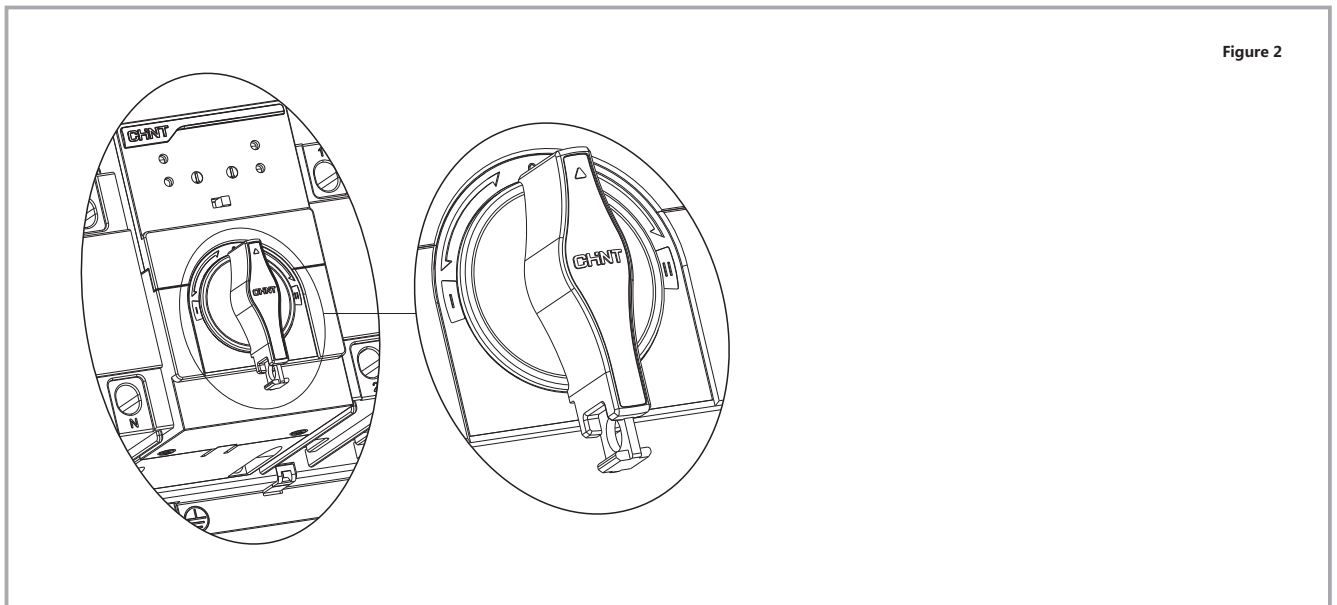

5. Functions and characteristics

Functional description of NXZ (H) M

Operation interface of the display module of controller

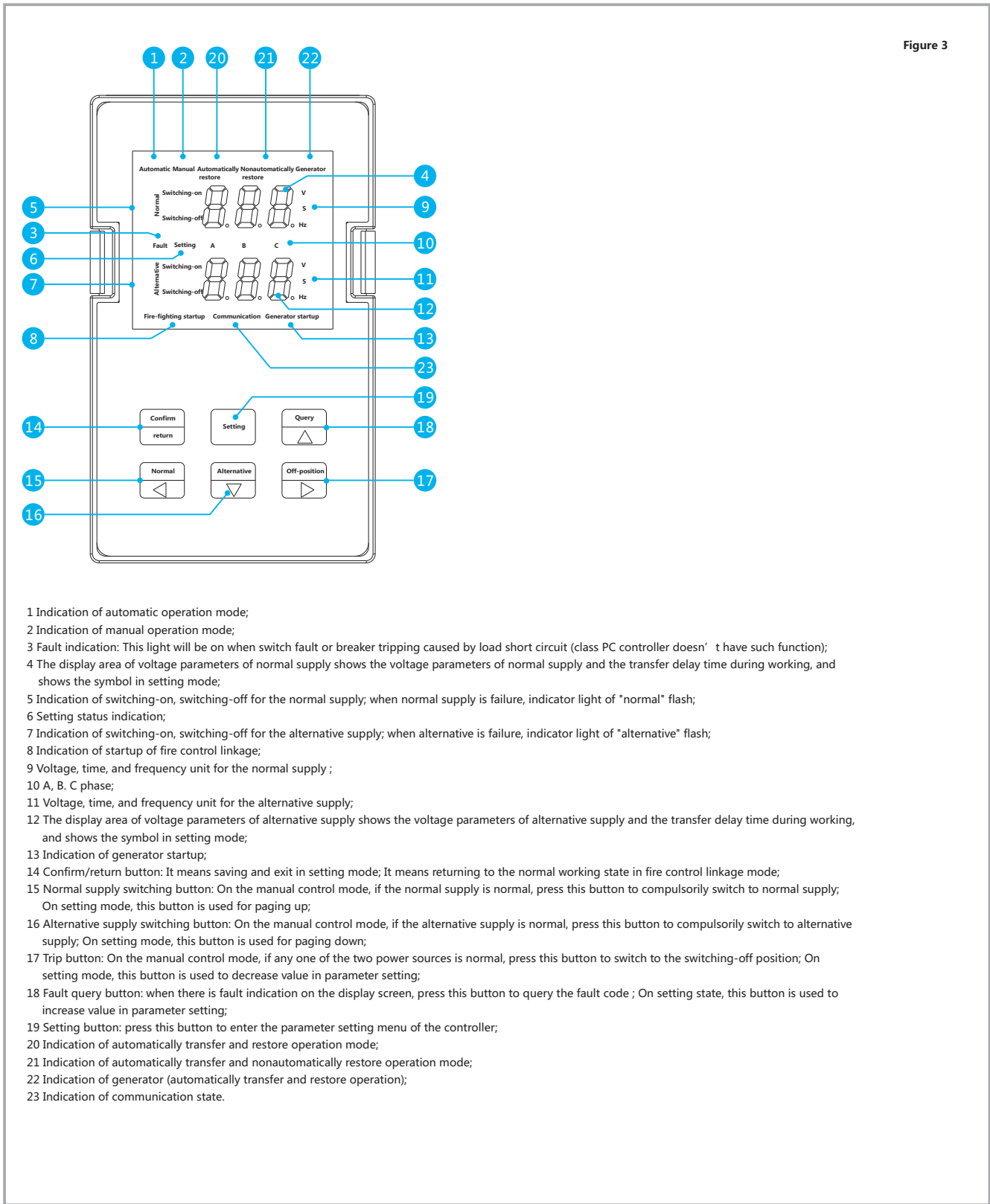

- 1 Indication of automatic operation mode;
- 2 Indication of manual operation mode;
- 3 Fault indication: This light will be on when switch fault or breaker tripping caused by load short circuit (class PC controller doesn't have such function);
- 4 The display area of voltage parameters of normal supply shows the voltage parameters of normal supply and the transfer delay time during working, and shows the symbol in setting mode;
- 5 Indication of switching-on, switching-off for the normal supply; when normal supply is failure, indicator light of "normal" flash;
- 6 Setting status indication;
- 7 Indication of switching-on, switching-off for the alternative supply; when alternative is failure, indicator light of "alternative" flash;
- 8 Indication of startup of fire control linkage;
- 9 Voltage, time, and frequency unit for the normal supply ;
- 10 A, B, C phase;
- 11 Voltage, time, and frequency unit for the alternative supply;
- 12 The display area of voltage parameters of alternative supply shows the voltage parameters of alternative supply and the transfer delay time during working, and shows the symbol in setting mode;
- 13 Indication of generator startup;
- 14 Confirm/return button: It means saving and exit in setting mode; It means returning to the normal working state in fire control linkage mode;
- 15 Normal supply switching button: On the manual control mode, if the normal supply is normal, press this button to compulsorily switch to normal supply; On setting mode, this button is used for paging up;
- 16 Alternative supply switching button: On the manual control mode, if the alternative supply is normal, press this button to compulsorily switch to alternative supply; On setting mode, this button is used for paging down;
- 17 Trip button: On the manual control mode, if any one of the two power sources is normal, press this button to switch to the switching-off position; On setting mode, this button is used to decrease value in parameter setting;
- 18 Fault query button: when there is fault indication on the display screen, press this button to query the fault code ; On setting state, this button is used to increase value in parameter setting;
- 19 Setting button: press this button to enter the parameter setting menu of the controller;
- 20 Indication of automatically transfer and restore operation mode;
- 21 Indication of automatically transfer and nonautomatically restore operation mode;
- 22 Indication of generator (automatically transfer and restore operation);
- 23 Indication of communication state.

Parameter setting of the display module of controller

Figure 4

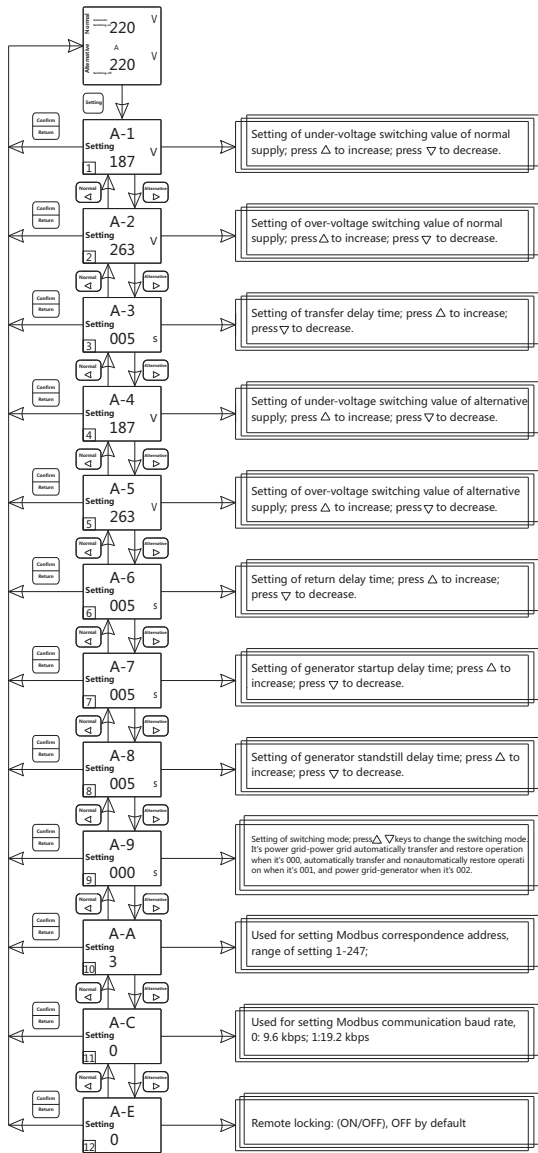

Operation interface for parameter setting of controller

- 1 Setting of under-voltage switching value: Default to 187V ;user-settable 160V-200V;
- 2 Setting of over-voltage switching value: Default to 263V ; user-settable 240V-290V;
- 3 Transfer delay setting: Default to 5s; user-settable 0s-180s;
- 4 Return delay setting: Default to 5s; user-settable 0s-180s;
- 5 Generator startup delay setting: Default to 5s; user-settable 0s-180s;
- 6 Generator standstill delay setting: Default to 5s; user-settable 0s-180s;

■ Note of buttons:

Pressure setup key when the controller is working, and the screen shows the parameter setting menu. Press " \triangleleft " " \triangleright " in the setting menu to turn up or down. Press "Confirm/return" key to exit from menu setting; press " ∇ " " Δ " to revise parameter.



6. Mode of connection of the main part and controller

Mode of connection of NXZB and NXZHB

Product wiring

The incoming line is connected from the top of product; the outgoing line is connected from the bottom of product; the product can be installed vertically or horizontally.

Wiring as follows. The power phase sequence shall be correct; in particular, N pole shall not be wrongly connected.

The connecting wire (electric cable) adopts single core Polyvinyl chloride (PVC) insulated conductor or copper bar of the equivalent effect.

Advice as follows:

Cross-sectional area of copper conductor

Safe ampacity (A)	20	25	32	40	50	63
Cross-sectional area of copper conductor (mm ²)	2.5	4	6	10	10	16

3P product

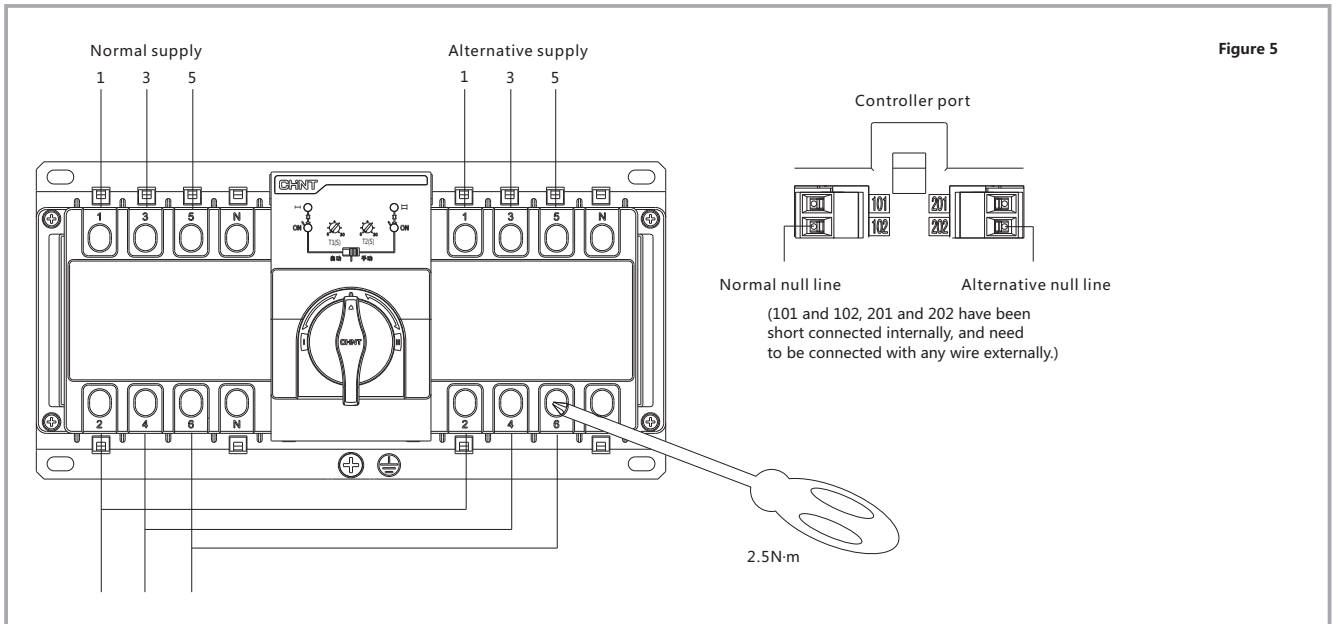

Figure 5

4P product

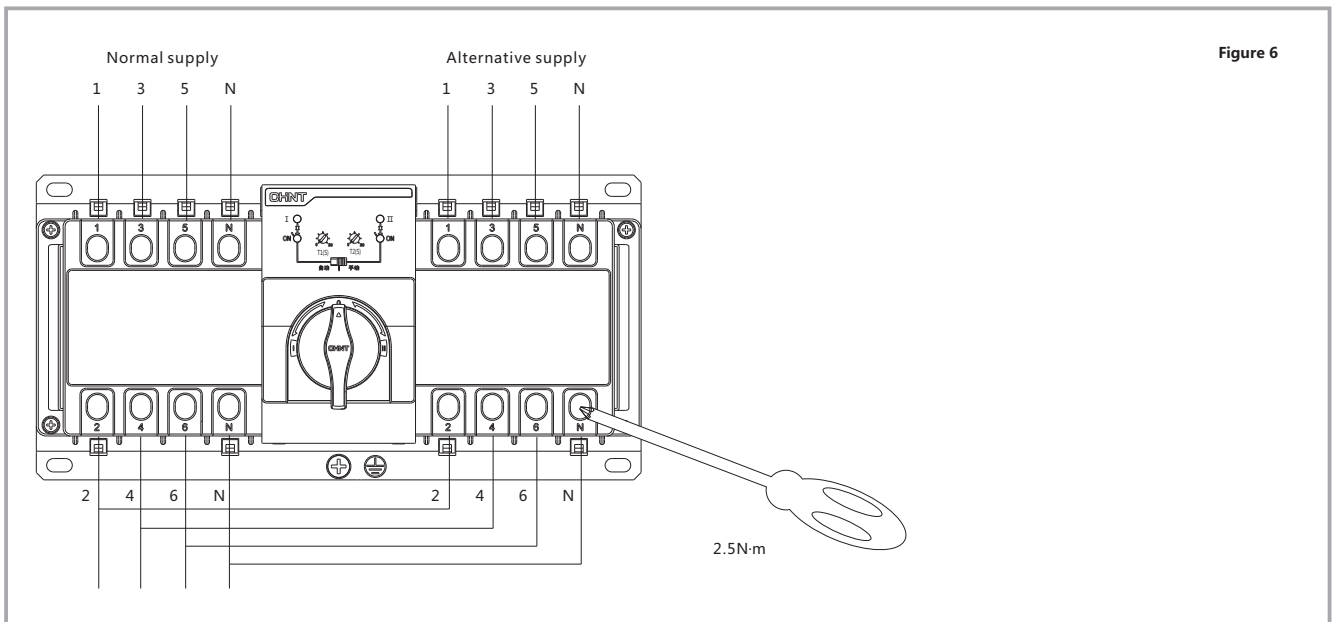
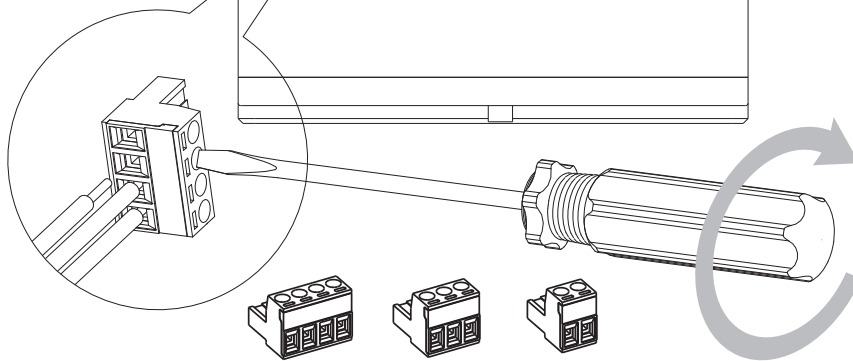
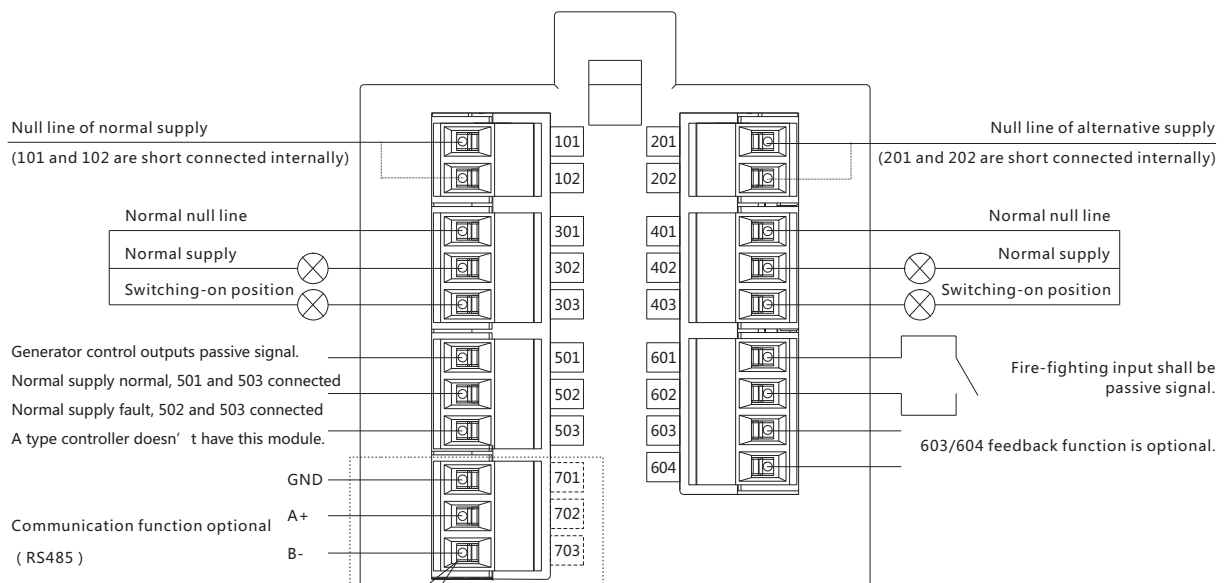

Figure 6

Signal and control terminal wiring

Figure 7



7. Mode of connection of the main part and controller

Mode of connection of NXZM and NXZHM

Product incoming line mode: incoming line at the top of product; outgoing line at the bottom of product
 Installation mode: vertically or horizontally

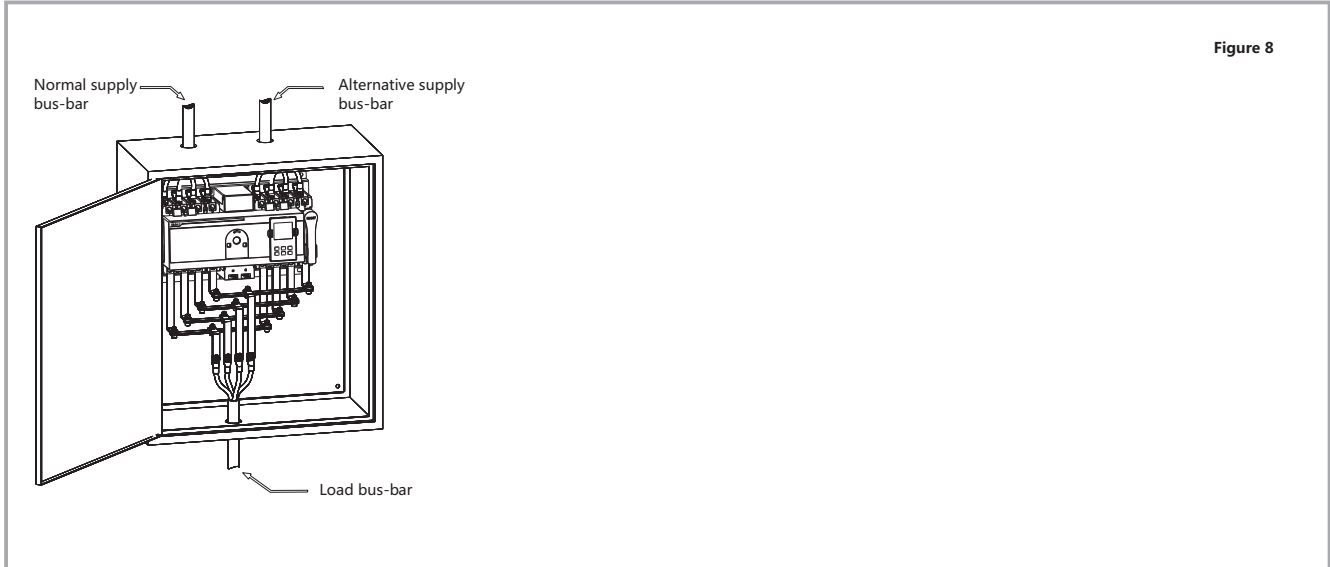

Product wiring

3P

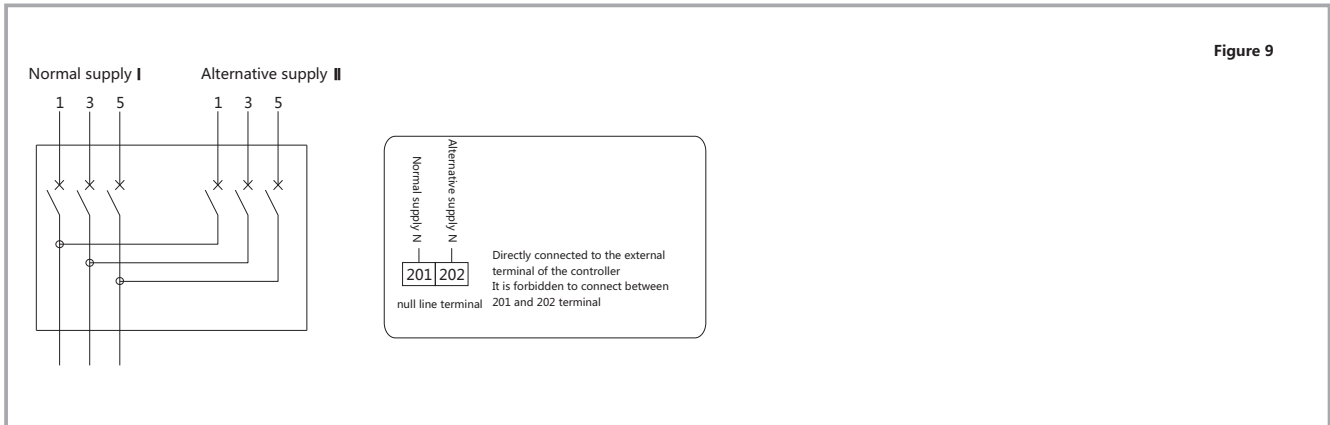

4P

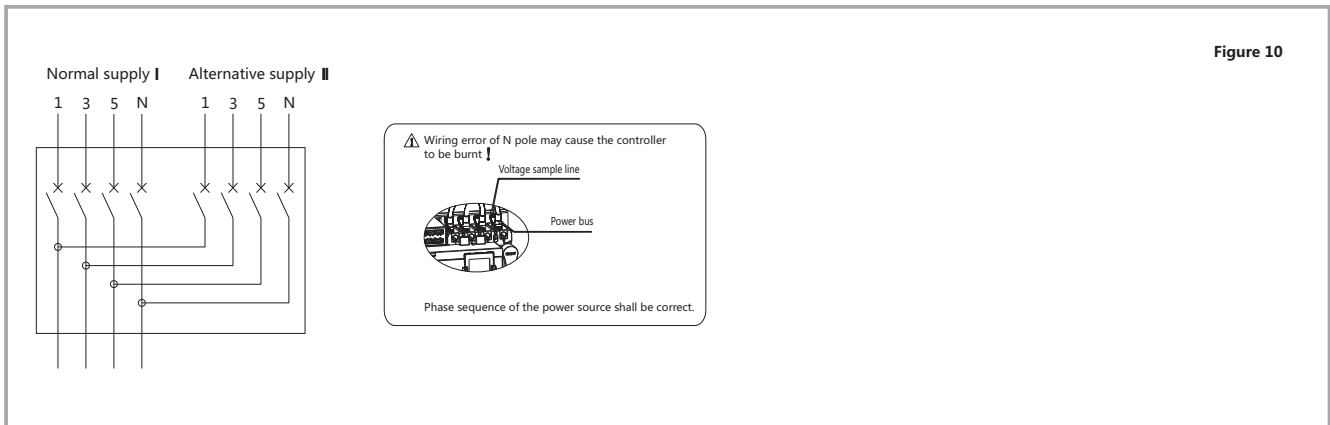

Wire connection

Figure 11

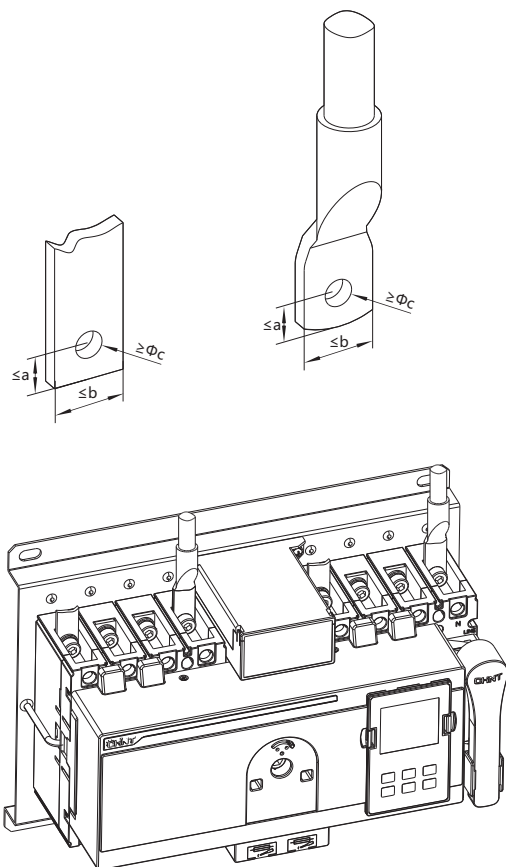

Unit: mm

Product code	a	b	c
MXZ(H)M-63, 125	6.5	14	5.5 (≤63A)
	7.5	17	6.5 (> 63A)
MXZ(H)M-160	7.5	14.5	8.5
MXZ(H)M-250, 320	10	23	8.5
MXZ(H)M-400, 630	10.5	30.5	10.5
MXZ(H)M-800	15	43	14



8. Mode of connection of the main part and controller

Installation of interphase barrier

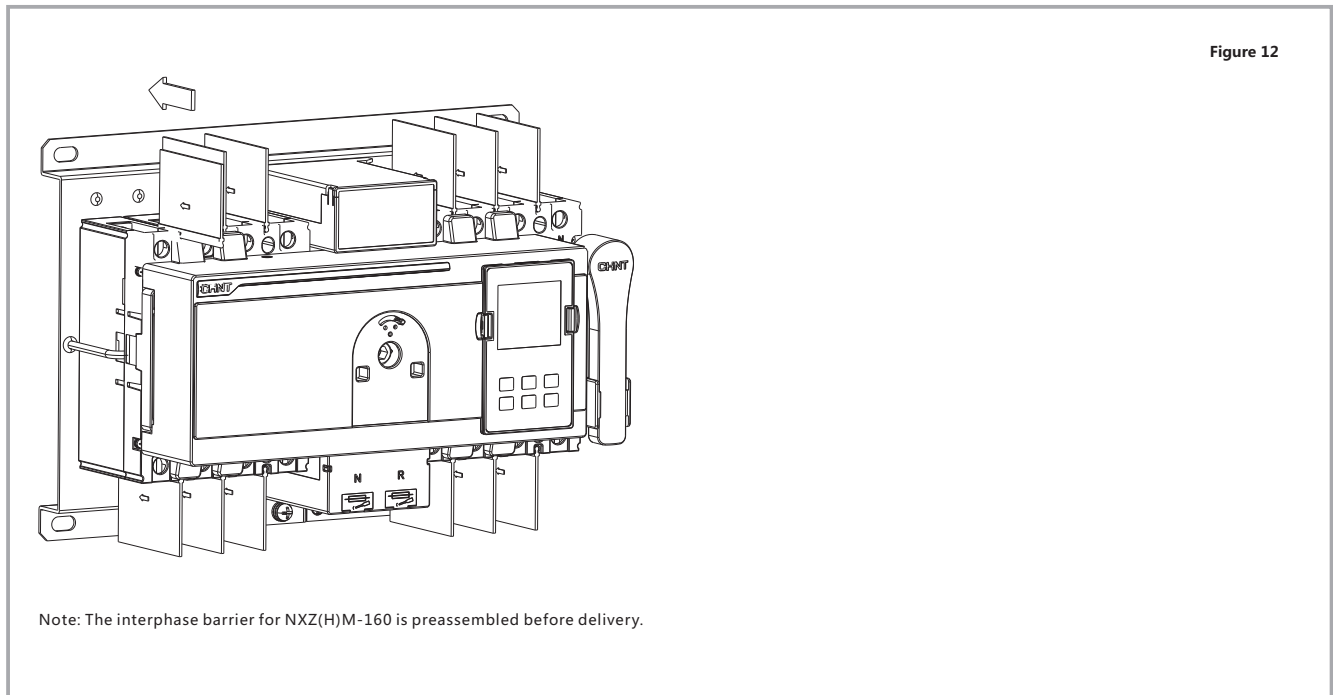

Split type installation of the display module (cabinet door)

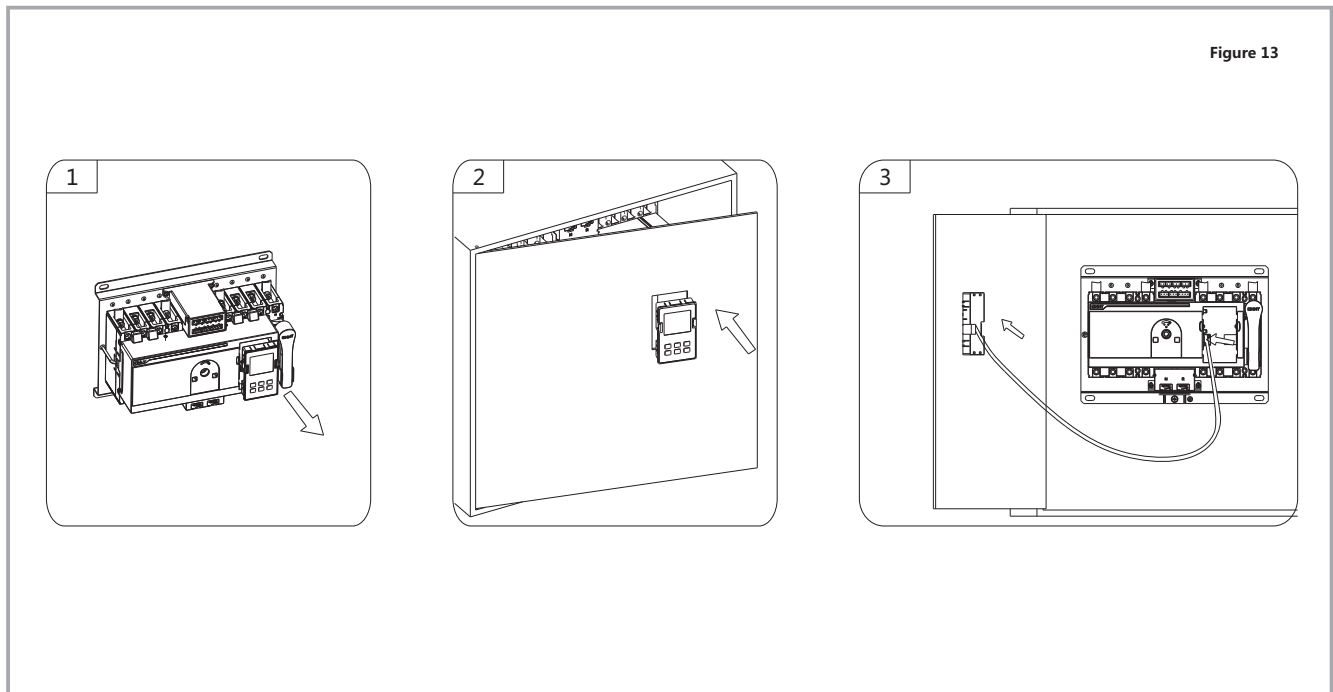

Signal and control terminal wiring

Figure 14

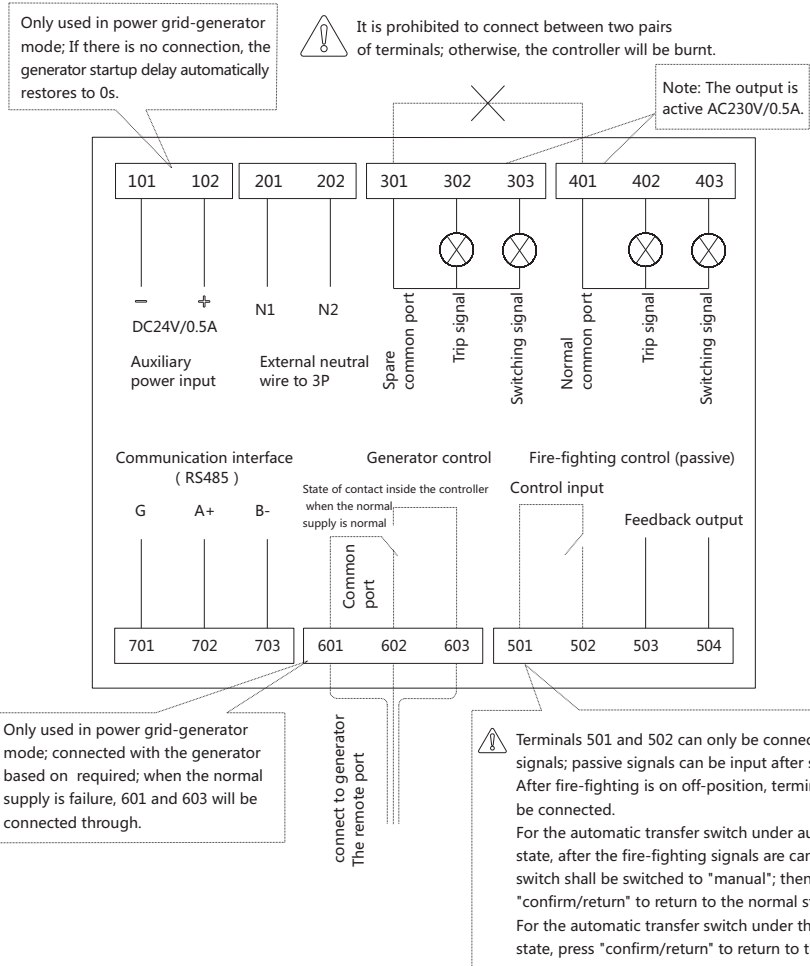

Note: Type A controller has no fire-fighting feedback and generator control function.



9. Overall and installation dimension

Overall and installation dimension of NXZB and NXZHB

Overall and installation dimension
(the dimension of 3P product and 4P is the same)

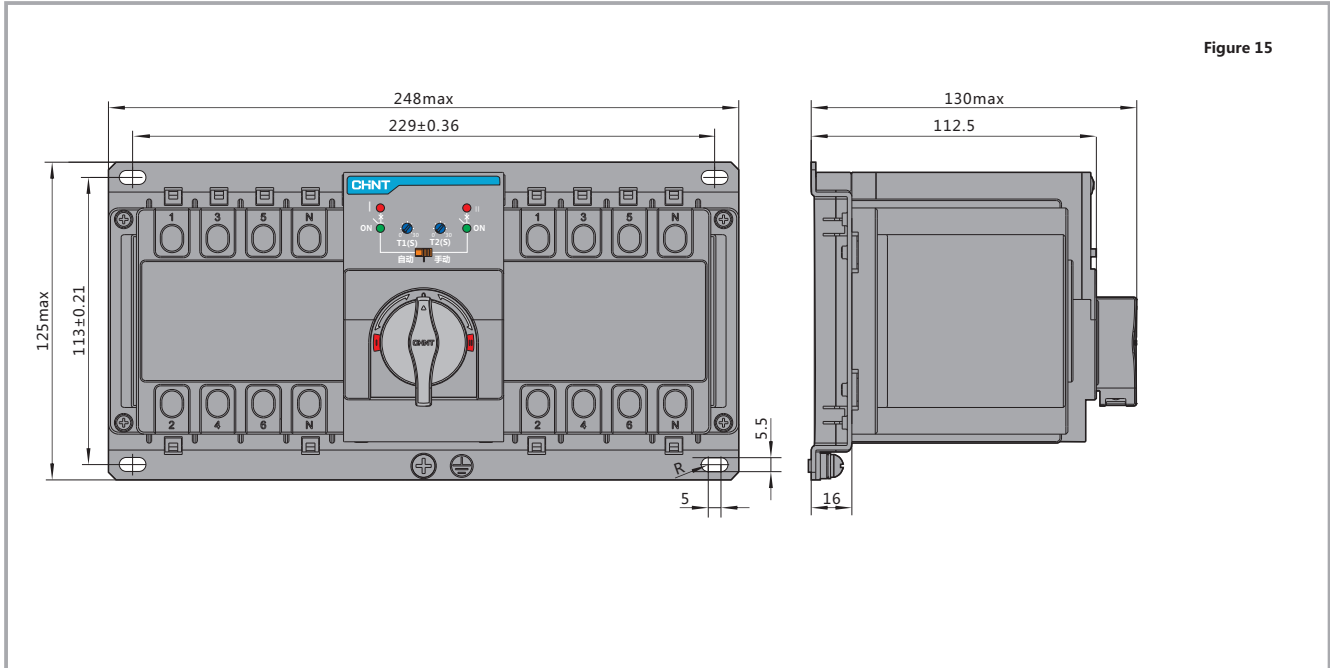

Figure 15

Overall and installation dimension of NXZM and NXZHM

Overall and installation dimension

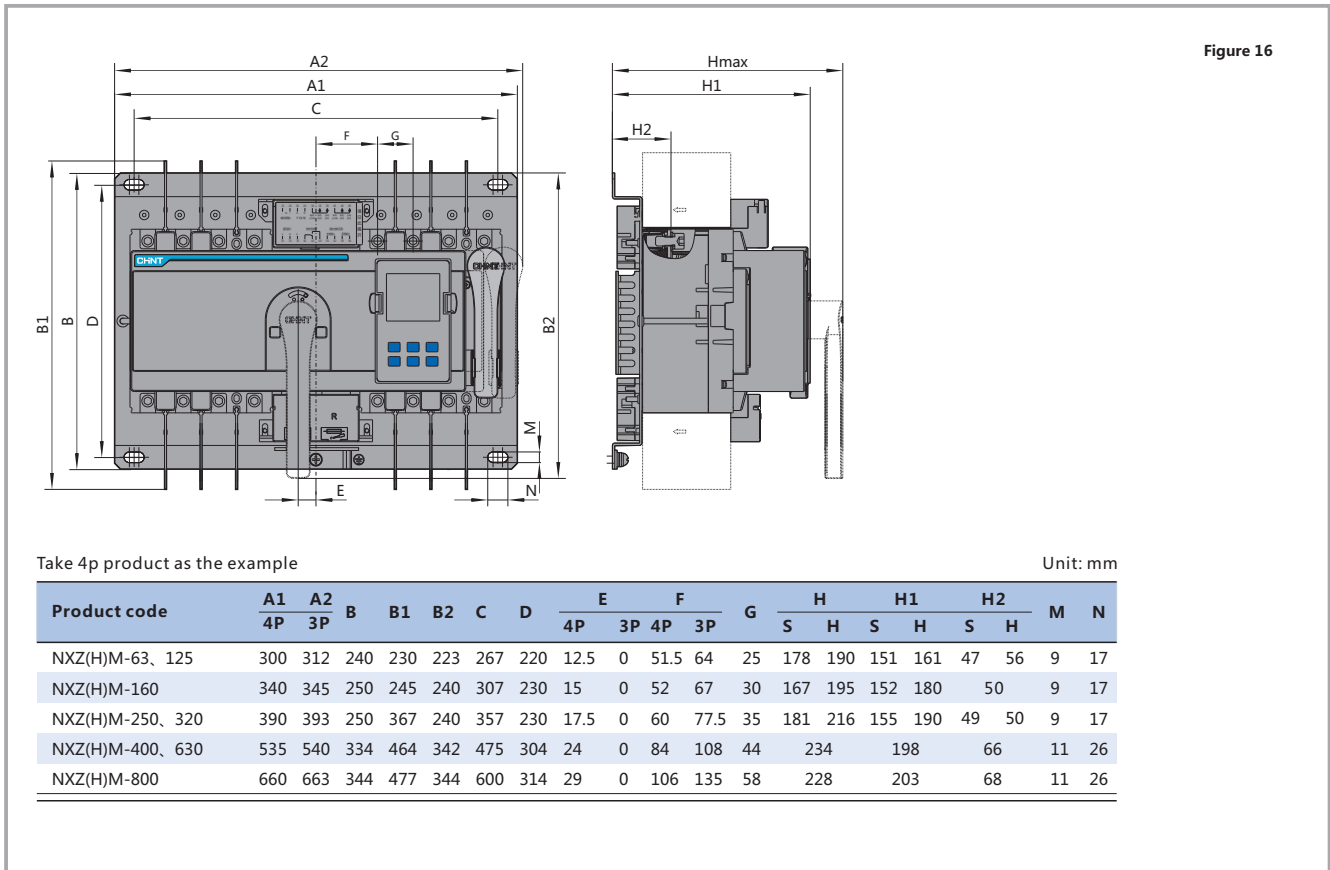

Figure 16

Overall dimension of split type module (unit: mm)

Figure 17

